

# System 400

## Wireless Audio System

### Operating Instructions

(For Full-Duplex and Half-Duplex Operations)

6675 Mesa Ridge Road, San Diego, CA 92121 USA  
Phone: 1-800-848-4468 Fax: (858) 552-0172



**HM ELECTRONICS, INC.**

# Table of Contents

I.	GENERAL .....	1
II.	EQUIPMENT FUNCTIONS AND USE .....	1
	A. Base Station .....	1
	B. COM400CC COMMUNICATOR® .....	2
	1. Controls and Connector .....	2
	2. Wearing the COM400CC COMMUNICATOR® .....	3
	3. Charging the COM400CC Batteries .....	4
	C. COM400BP COMMUNICATOR® .....	7
	1. Controls and Connector .....	7
	2. Wearing the COM400BP COMMUNICATOR® .....	8
	3. Charging the COM400BP Batteries .....	9
	D. COM430BP COMMUNICATOR® .....	12
	1. Communicator Controls .....	12
	2. Wearing the COM430BP COMMUNICATOR® .....	13
	3. Charging the COM430BP Batteries .....	14
III.	SYSTEM 400 OPERATION .....	18
	A. COMMUNICATOR® Operation .....	18
	B. Speed-Team Drive-Thru Operation .....	19
	C. Remote Display Operation .....	19
	D. Message Repeater Operation and Setup .....	19
IV.	HOW TO CARE FOR THE EQUIPMENT .....	20
	A. The COMMUNICATOR® .....	20
	1. Proper Handling of Headset Cables and Connectors .....	20
	2. Cleaning the Equipment .....	20
	B. The Battery Charger .....	20
V.	IN CASE OF PROBLEMS .....	21
VI.	SPECIFICATIONS .....	24
VII.	ACCESSORIES AND OPTIONAL EQUIPMENT .....	27
VIII.	FCC NOTICE .....	27

# List of Figures

Figure	Title	Page
1	System 400 Base Station	1
2	COM400CC COMMUNICATOR®	2
3	COM400CC control buttons	2
4	Cable connectors showing matching pin positions	2
5	Correct wearing of the COM400CC	3
6	Remove and replace Communicator batteries	4
7	Inserting a battery into the AC900 Battery Charger	4
8	Battery charging indicator lights	5
9	Battery going into AC900 storage port	5
10	COM400CC battery charging in the AC910 Battery Charger	6
11	COM400BP COMMUNICATOR®	7
12	COM400BP controls, connector and indicator light	7
13	Plug the headset-cable connector into the cable receptacle	8
14	Insert belt through belt loop on back of Communicator pouch	8
15	Correct wearing of Communicator headset	8
16	Installing the battery	9
17	Opening the battery compartment	9
18	AC420 Battery Charger shown with a properly installed battery	10
19	COM400BP battery charging in the AC910 Battery Charger	11
20	COM430BP COMMUNICATOR®	12
21	Communicator controls	12
22	Communicator transceiver in pouch	13
23	Correct wearing of the COM430BP	13
24	Installing the COM430BP battery	14
25	Opening the COM430BP battery compartment	14
26	HS30 Headset	15
27	HS30 Headset transceiver	15
28	AC30 Battery Charger	16
29	AC930 Battery Charger	17
30	Base station circuit boards	23

**In the event of an electrical power outage**

such as from a lightning storm or power generator failure, if you experience problems with your HME equipment after the electricity comes on again, unplug the AC power adapters from their electrical outlets, then plug them back in.

# I. GENERAL

The System 400 is a wireless audio system primarily for use at quick-service restaurants.

# II. EQUIPMENT FUNCTIONS AND USE

## A. Base Station

### Front –

#### System indicator lights

- ! **POWER light** is on when the base station has power.
- ! **MESSAGE RECORD light** is on **RED** when the base station is ready to record message #1 for the message repeater, and blinking **RED** while message #1 is being recorded. It is on **GREEN** when the base station is ready to record message #2 for the message repeater, and blinking **GREEN** while message #2 is being recorded. The MESSAGE REPEATER button must be IN.
- ! **RECEIVE light** is used only for troubleshooting, but is also on during channel-A and channel-B transmissions.
- ! **“A” light** is on during channel-A transmission.
- ! **“B” light** is on during channel-B transmission.
- ! **VEHICLE light** is on when a vehicle is present in the drive-thru lane or when the system is in vehicle-detect override.

### Bottom –

- ! **PUSH FOR RECORD MODE button;** must be pushed IN and released once to prepare the base station to record message #1 for the message repeater, or pushed IN and released twice to record message #2.
- ! **MESSAGE REPEATER button;** must be IN to use the message repeater, OUT when the message repeater is not being used.
- ! **SPEED TEAM button;** must be IN for speed-team operation, OUT for normal drive-thru operation
- ! **VEHICLE DETECTOR button;** to override a vehicle detector, push and leave IN: to reset vehicle detector, push IN and leave In for 5 seconds, then push again and leave OUT for normal vehicle detection.

### Left Side –

- ! **WIRED/WIRELESS button;** must be OUT when using the wireless System 400, IN when using a wired backup system.

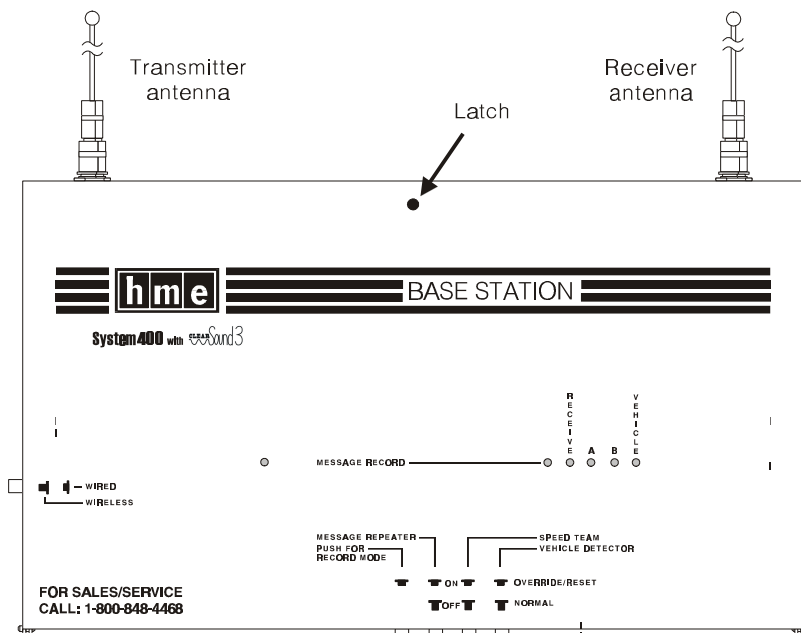

Figure 1. System 400 Base Station

## B. COM400CC COMMUNICATOR®

The COM400CC COMMUNICATOR® consists of a transceiver unit and a lightweight headset designed to be used with the HME Wireless Drive-Thru Audio System 400. The transceiver is worn around the collar, and the headset plugs into a connector on the transceiver unit.



Figure 2. COM400CC COMMUNICATOR®

### 1. Controls and Connector

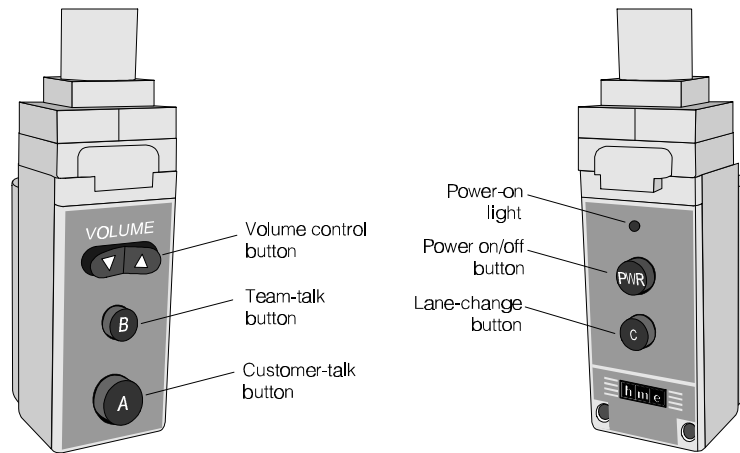

Figure 3. COM400CC control buttons.

Plug the headset cable connector into the cable connector on the COM400CC collar unit, as shown in Figure 4. Be careful to correctly match the positions of the pins inside the connector.

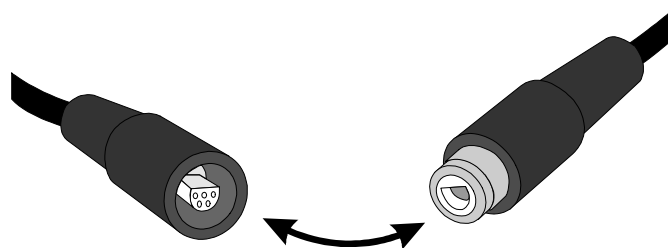
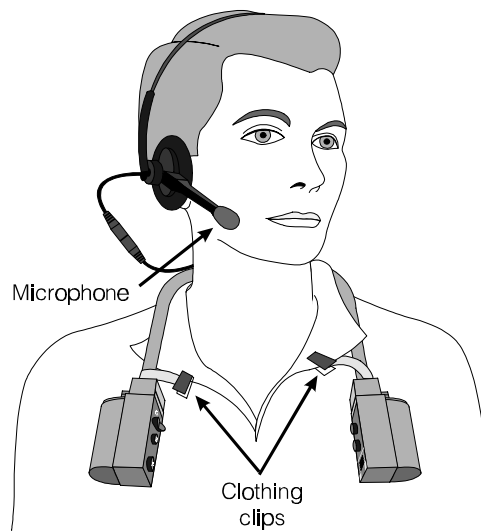

Figure 4. Cable connectors showing matching pin positions

## 2. Wearing the COM400CC COMMUNICATOR®

- ! Place the Communicator collar unit around your neck and put the headset on your head as shown in Figure 5.
- ! Adjust the headset band so it rests securely on top of your head, with the microphone to the side of your mouth.
- ! Adjust the Communicator so it fits comfortably around your collar.
- ! Fasten the clothing clips to your collar as shown in Figure 5.



**Figure 5. Correct wearing of the COM400CC**

### 3. Charging the COM400CC Batteries

When there are good batteries in the COMMUNICATOR® and the power is on, the red light above the power (PWR) button will be lit. This light only indicates the power is on. It does not indicate how much power is left in the batteries. As the batteries weaken during routine use, you will hear a repeating beep in the earpiece, indicating the batteries need to be replaced. When this happens, remove the battery from the Communicator as shown in Figure 6. Place both batteries in the AC900 Battery Charger for recharging. Refer to Figures 7 through 9. Replace the batteries in the Communicator with fresh, fully charged batteries. Typical battery life with normal use is 8 to 10 hours.

**CAUTION:** To prevent damage, turn Communicator OFF before removing or installing batteries.

#### Installing and Removing Communicator Batteries:

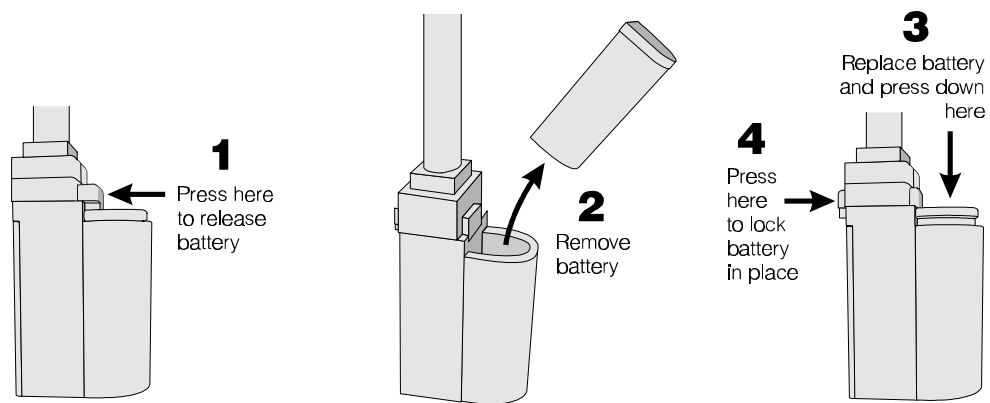

Figure 6. Remove and replace Communicator battery

#### Charging COM400CC Batteries in the AC900 Battery Charger:

Place up to four COM400CC batteries in the charger for charging at a time. See Figure 7. The red Charging light, adjacent to a battery being charged will go on and remain on while the battery is charging. Routine battery charging takes up to 3 hours.

**NOTE:** The COM400CC uses “smart batteries.” That means each battery maintains a history of the number of times it has been charged. The AC900 Battery Charger reads and updates this history each time a battery is charged. This information is used to automatically initiate conditioning cycles, which improve the battery’s performance and prolong its life. A conditioning cycle consists of a complete discharge before a battery is charged. This happens each time the battery history indicates it has been charged 10 times since the last conditioning cycle. While a battery is discharging, the red Charging light next to it will blink on and off at 2-second intervals. The conditioning cycle takes up to 6 hours.

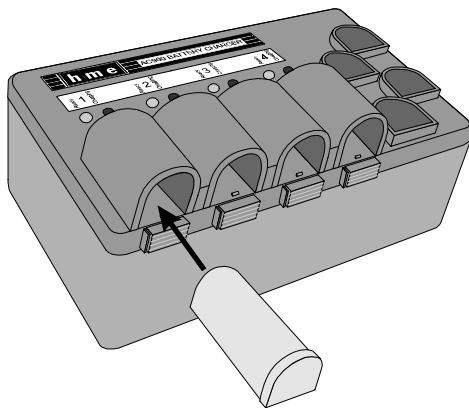
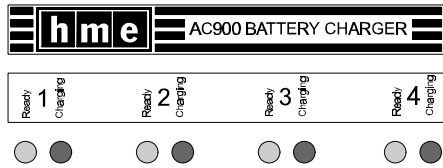

Figure 7. Inserting a battery into the AC900 Battery Charger



When a battery is fully charged and ready for use, its red “Charging” light will go off and the green “Ready” light next to it will go on.

**Figure 8.**  
Battery charging indicator lights

**CAUTION:** Do not remove batteries from the charger until the green **READY** light is lit, or the charger will reset and the charge cycle will begin again.

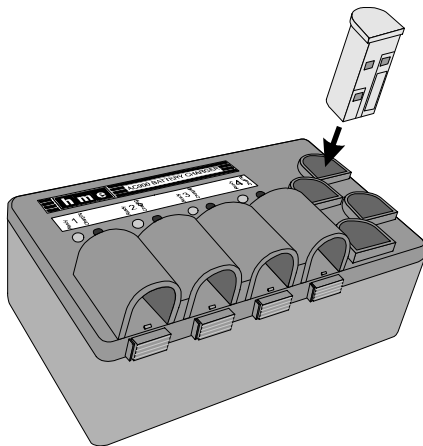

To remove a fully charged battery from the battery charger, push the battery from the end near the status lights.

Store fully charged batteries in the storage ports on the right side of charger until you need them, as shown in Figure 9.

**Figure 9.**  
Battery going into AC900 storage port

CHARGING LIGHT STATUS TABLE – WITH BATTERY INSERTED		
CHARGING LIGHT	WHAT IT MEANS	WHAT TO DO
Red blinks: 2 times quick - 3 seconds off	Discharge error	Either the battery or the charger has a problem. Mark the battery and retry in a different charging port. The battery is faulty if it has the same problem in a different port AND a known-good battery passes in the same ports. The charger circuitry is faulty if a known-good BATTERY fails in the same ports.
Red blinks: 3 times quick - 3 seconds off	Charging error	
Red blinks: 4 times quick - 2 seconds off	Low-battery error	
Red blinks: 5 times quick - 2 seconds off	Charging error	
Green blinks: 2 second on - 2 second off	Read-write error	
Green blinks: 3 times quick - 3 seconds on	Memory full	
Red and Green blink alternately	Authentication error	



## Charging COM400CC batteries in the AC910 Battery Charger:

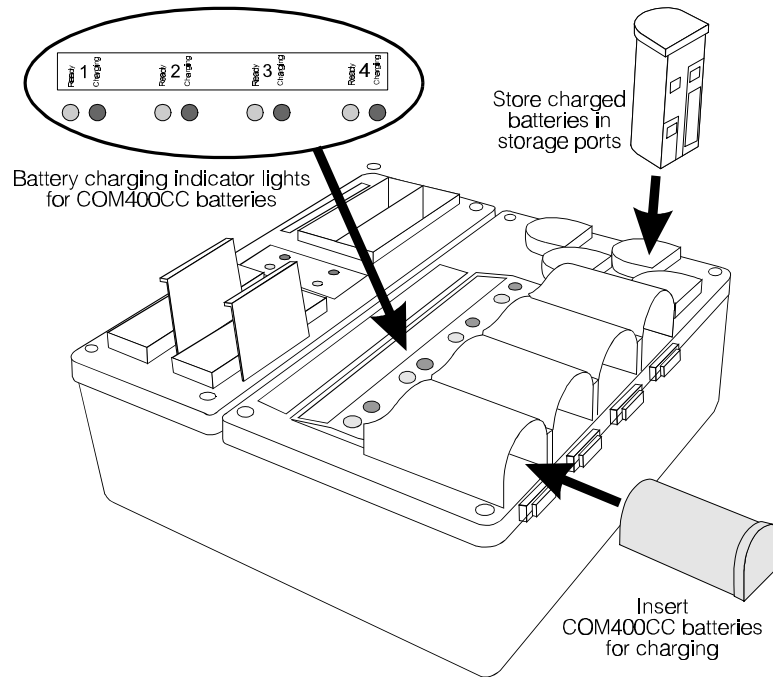

**Figure 10.**  
**COM400CC battery charging in the AC910 Battery Charger**

Place up to four COM400CC batteries in the charger for charging at a time. The red Charging light, adjacent to a battery being charged will blink for a few seconds when the battery is placed in the charger, then will go on and remain on while the battery is charging.

**NOTE:** The COM400CC uses “smart batteries.” That means each battery will retain charging information that will cause it to automatically discharge completely before being recharged, every tenth time it is placed in the charger. This will improve the battery’s performance and life. While a battery is discharging, its red Charging light will blink on and off at 2 second intervals.

When the battery is fully charged and ready for use, the red light will go off and the green Ready light adjacent to the battery will go on.

To remove fully charged batteries from the battery charger, push the battery from the end near the status lights. Store fully charged batteries in the storage ports until you need them.

## C. COM400BP COMMUNICATOR®

The COM400BP COMMUNICATOR® consists of a belt-pac transceiver unit and a lightweight headset designed to be used with the HME Wireless Drive-Thru Audio System 400. The Communicator is worn around the user's waist, and the headset plugs into a connector on the transceiver unit.

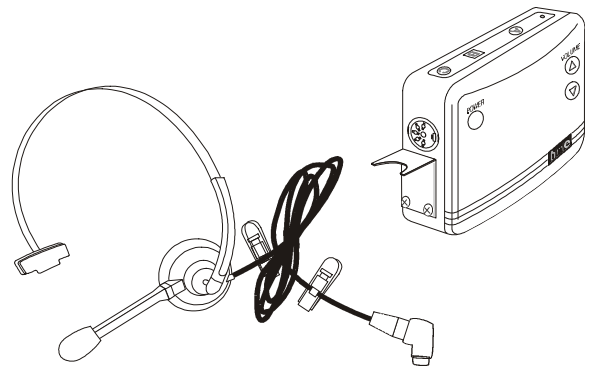

Figure 11. COM400BP COMMUNICATOR®

### 1. Controls and Connector

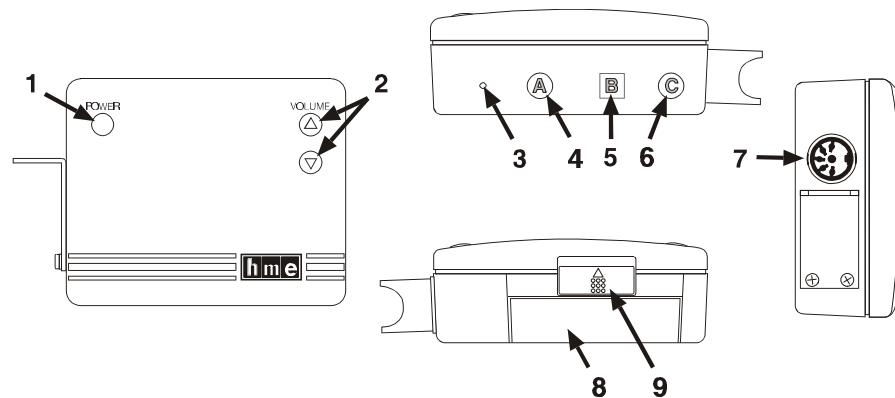
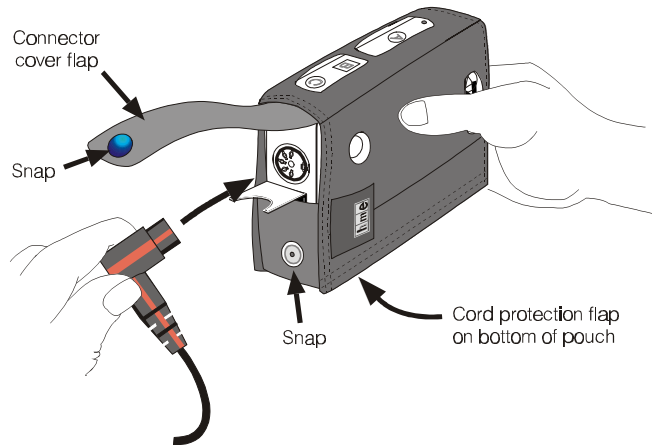

Figure 12. COM400BP controls, connector and indicator light

- 1 – **POWER button:** turns Communicator on and off.
- 2 – **VOLUME buttons:** adjust listening level in earpiece.
- 3 – **Power-on light:** lights when power goes on, and remains lit until battery needs replacing or Communicator is turned off. The power-on light blinks when transmitting on "A" or "B" channel.
- 4 – **Button A:** allows two-way communication when pushed and held; when it is released, the user can listen only.
- 5 – **Button B:** must be pushed and held to talk, and released to listen.
- 6 – **Button C:** used to change lanes in dual-lane operations.
- 7 – **5-pin DIN receptacle:** receptacle for earpiece/microphone cable connector.
- 8 – **Battery:** provides power for the transceiver unit.
- 9 – **Battery release latch:** slides to release battery for removal, and snaps in place when a battery is inserted to secure battery in Communicator.

## 2. Wearing the COM400BP COMMUNICATOR®

Plug the headset-cable connector into the receptacle on the Communicator transceiver as shown in Figure 13. The connector is keyed so it can only be inserted in the correct position, with the cord extending downward. Loosen the snap on the cord protection flap and resnap it with the flap over the cord.



**Figure 13. Plug the headset-cable connector into the cable receptacle**

Insert the Communicator belt through the loop on back of the Communicator pouch as shown in Figure 14, and fasten the belt securely around your waist. The Communicator transceiver can be worn over either your right or left hip.

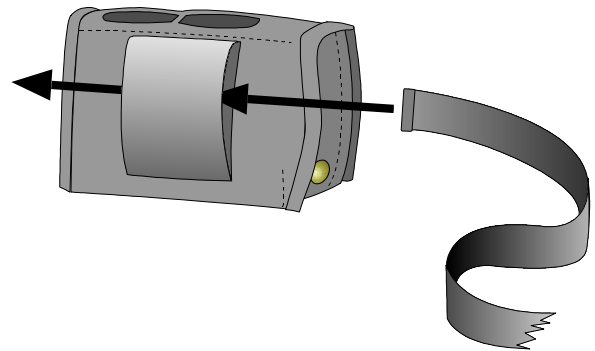

**Figure 14. Insert belt through belt loop on back of Communicator pouch**



**Figure 15. Correct wearing of the Communicator headset**

Put the headset on your head and clip one of the clothing clips to your collar as shown in Figure 15. Clip the other clothing clip to the back of your shirt, above your waist. Position the microphone approximately 2 inches (50.8 mm) from your mouth.

### 3. Charging the COM400BP Batteries

When a good battery is in the COMMUNICATOR® and the power is on, the red light on top of the unit will be lit. This light only indicates the power is on. It does not indicate how much power is left in the battery. As a battery weakens during routine use, you will hear a repeating beep in the earpiece, indicating the battery needs to be replaced. Typical battery life with normal use is 8 to 10 hours.

**CAUTION: To prevent damage, turn Communicator OFF before removing batteries.**

#### Installing and Removing Communicator Batteries:

- ! Install a fully charged battery in the battery compartment with the arrow on the battery pointing out as shown in Figure 16. Slide it into the tracks on both sides of the compartment until its catch clicks securely in place.

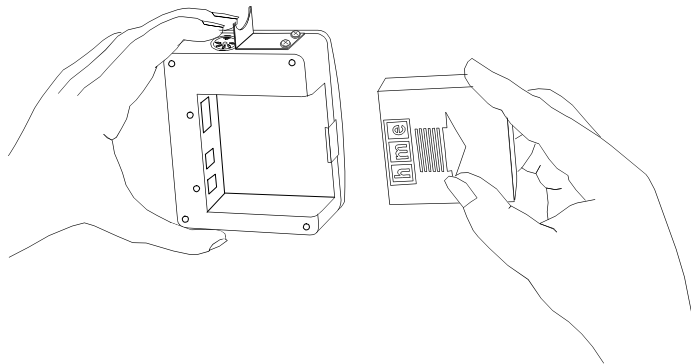

**Figure 16. Installing the battery**

- ! To remove the battery from a Communicator, slide the battery latch open and push the battery in the direction of the large arrow on the battery as shown in Figure 17.

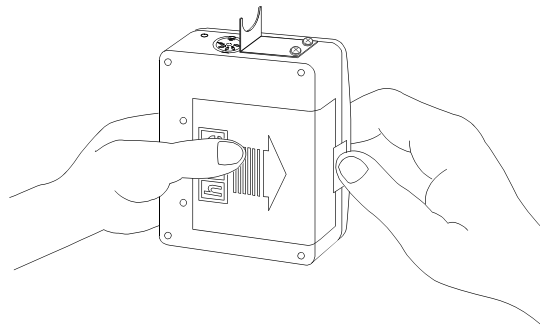
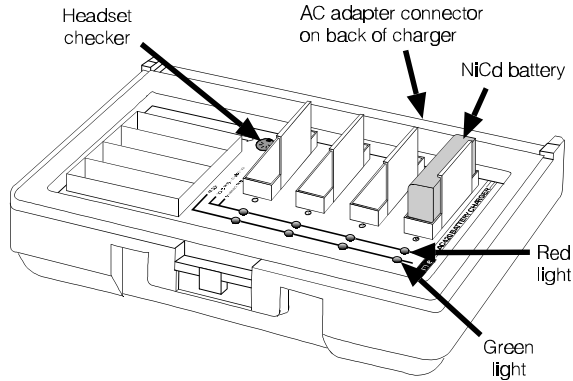

**Figure 17. Opening the battery compartment**

## Charging COM400BP Batteries in the AC420 Battery Charger:

Place up to four batteries in the charger to charge at the same time, as shown in Figure 18. A few seconds after each battery is placed in the charger, the red CHARGING light on the panel adjacent to the battery, will indicate the battery charging status. See the CHARGING LIGHT STATUS TABLE for a detailed explanation of what is happening. When a battery is fully charged, the green READY light on the panel adjacent to it will light. **(approximately 4 hours)** It can then be placed back into a Communicator.

**CAUTION: Do not remove batteries from the charger until the green READY light is lit, or the charger will reset and the charge cycle will begin again.**



**Figure 18.**  
AC420 Battery Charger shown with a properly installed battery

**Top –**

**Red lights** indicate charging status of batteries below the lights, as shown on the Charging Light Status Table below.

**Green lights** indicate batteries below the lights are fully charged and ready for use.

**Headset checker** is used to check headsets for normal operation. Plug the headset cable connector into the headset connector receptacle and speak into the headset microphone. If the headset is operating normally, you will hear your own voice in the earpiece. If the headset is defective, you will hear nothing.

**Back –**

**AC adapter connector** is for connecting the AC adapter cable to the charger.

CHARGING LIGHT STATUS TABLE – WITH BATTERY INSERTED		
RED CHARGING LIGHT	WHAT IT MEANS	WHAT TO DO
OFF	Charger doesn't see the battery	See NOTE
STEADY ON	Battery is being charged	Wait. Do not remove battery.
BLINKS: 2 seconds ON; 2 seconds OFF	Battery is being discharged.	Wait. Do not remove battery.
BLINKS: 2 times quick; 3 seconds OFF	DISCHARGE ERROR	Battery is not discharging properly. See NOTE.
BLINKS: 3 times quick; 3 seconds OFF	CHARGING ERROR	Battery is not charging properly. See NOTE.
BLINKS: 4 times quick; 2 seconds OFF	LOW BATTERY ERROR	See NOTE.
BLINKS: 5 times quick; 2 seconds OFF	CHARGING ERROR	See NOTE.
<p><b>NOTE:</b> Either the battery or the charger has a problem. Mark the battery and retry in a different slot. The battery is faulty if it has the same problem in a different slot AND a known-good battery passes in the same slots. The charger circuitry is faulty if a known-good BATTERY fails in the same slots.</p>		

## Charging COM400BP batteries in the AC910 Battery Charger:

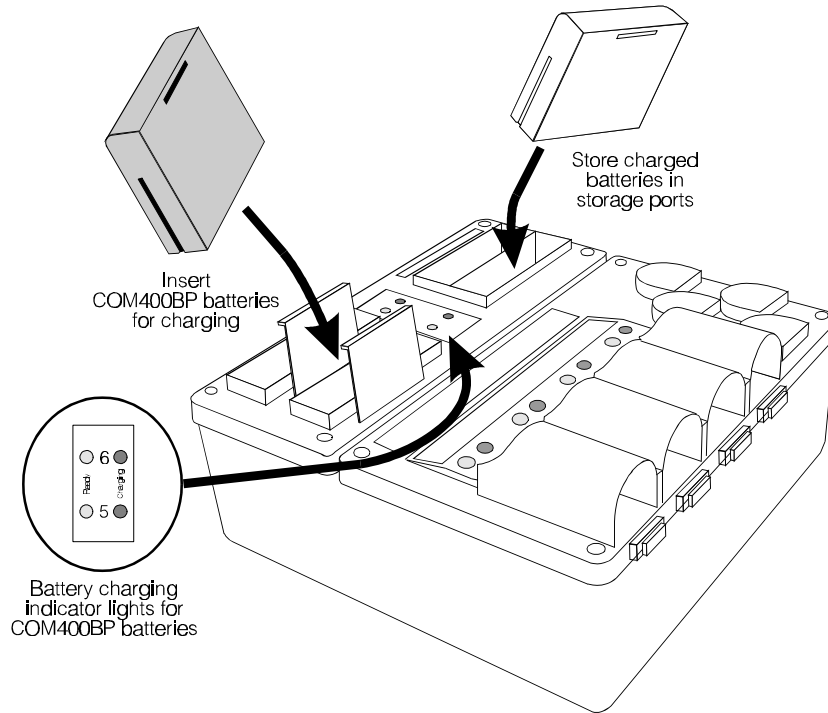

**Figure 19.**  
**COM400BP battery charging in the AC910 Battery Charger**

Place up to two COM400BP batteries in the charger to charge at the same time. A few seconds after each battery is placed in the charger, the red CHARGING light on the panel adjacent to the battery, will indicate the battery charging status. See the CHARGING LIGHT STATUS TABLE for a detailed explanation of what is happening. When a battery is fully charged, the green READY light on the panel adjacent to it will light. **(approximately 4 hours)** It can then be placed back into a COMMUNICATOR®.

**CAUTION:** *Do not remove batteries from the charger until the green READY light is lit, or the charger will reset and the charge cycle will begin again.*

## D. COM430BP COMMUNICATOR®

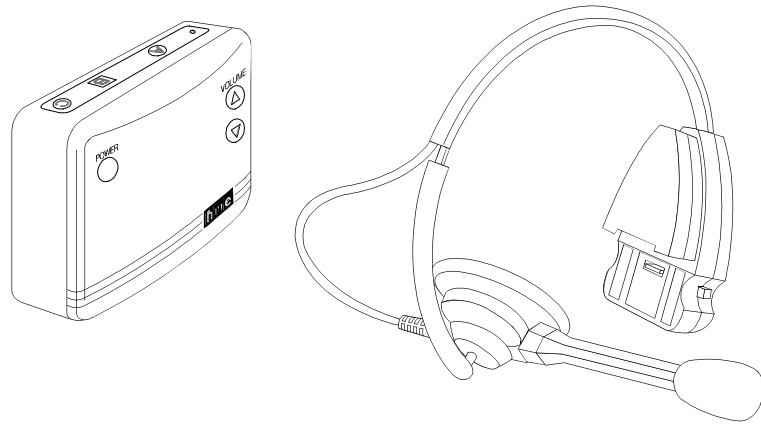

Figure 20. COM430BP COMMUNICATOR®

The COM430BP COMMUNICATOR® consists of a belt-pac transceiver unit and a wireless headset designed to be used with the HME Wireless Drive-Thru Audio System 400. The transceiver unit is worn in a pouch that clips to a belt or waistband at the user's waist.

### 1. Communicator Controls

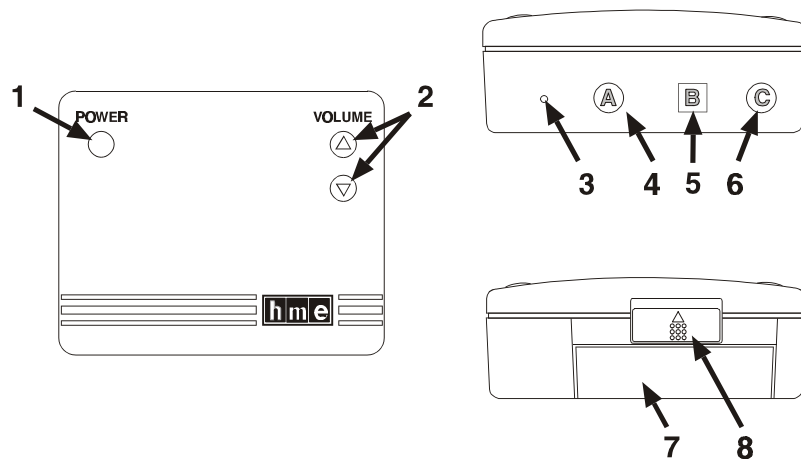

Figure 21. Communicator controls

- 1 – **Power button:** turns Communicator on and off.
- 2 – **Volume control buttons:** adjust listening level in earpiece.
- 3 – **Power-on light:** lights yellow when Communicator power goes on, and red when the HS30 Headset is also turned on. The power-on light also indicates when the Communicator is transmitting in single or dual-lane mode and when batteries need replacing.
- 4 – **Button A:** allows two-way communication when pushed and held; when it is released, the user can listen only.
- 5 – **Button B:** must be pushed and held to talk, and released to listen.
- 6 – **Button C:** used to change lanes in dual-lane operations.
- 7 – **Battery:** provides power for the transceiver unit.
- 8 – **Battery release latch:** slides to release battery for removal, and snaps in place when a battery is inserted to secure battery in Communicator.

## Handsfree mode –

**To turn Handsfree mode on:** With the Communicator OFF, press and hold B+ • (vol. up). Then press ON. You will hear "handsfree on."

**To turn Handsfree mode off:** With the Communicator OFF, press and hold B+– (vol. down). Then press ON. You will hear "handsfree off."

## 2. Wearing the COM430BP COMMUNICATOR®

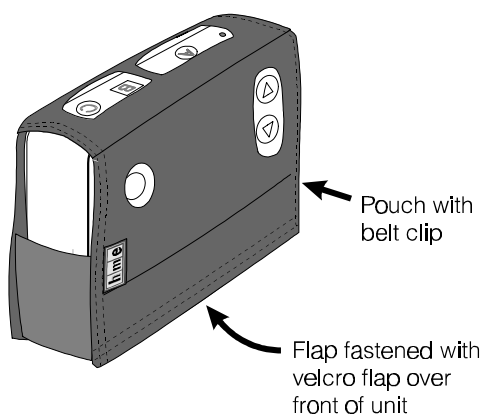

Place the belt-pac transceiver unit in its pouch and fasten the velcro flap securely over the front of it as shown in Figure 22. Squeeze open the belt clip on the back of the pouch and slide it over your belt or waist band, either on your right or left side.

**Figure 22.**  
**Communicator transceiver in pouch**

The headset should be worn with the transceiver side (the side opposite the microphone) on the same side as the belt-pac transceiver. For best reception, the belt-pac and headset should both be worn in their upright positions. Holding the earpiece, rotate the headset microphone so it is next to your mouth, as shown in Figure 23.

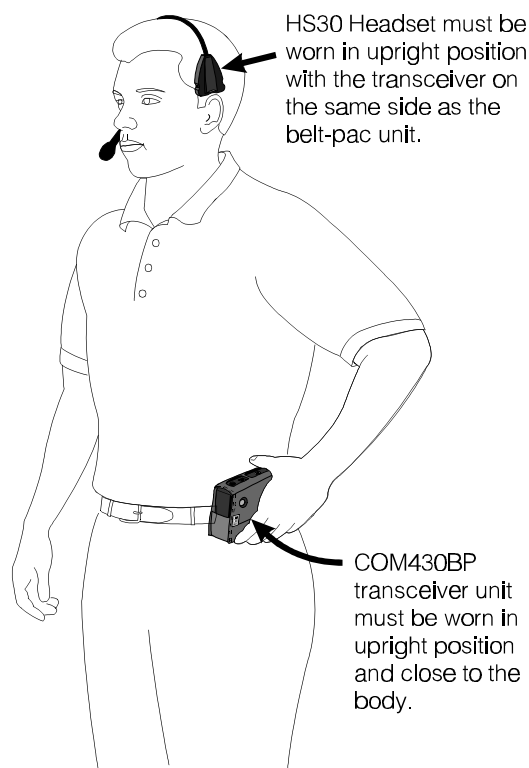

**Figure 23.**  
**Correct wearing of COM430BP**



### 3. Charging the COM430BP Batteries

When a good battery is in the COMMUNICATOR® transceiver and the power is on, the yellow light on top of the unit will be lit. When the HS30 Headset also has a good battery in it, and is on, the light on the belt-pac transceiver unit will be red. This light indicates the power is on, and that there is a link between the headset and belt-pac transceivers. It does not indicate how much power is left in the batteries.

**CAUTION:** *To prevent damage, turn Communicator OFF before removing or installing batteries.*

#### Installing and Removing COM430BP Batteries:

As a belt-pac transceiver battery weakens during routine use, you will hear a repeating beep in the earpiece, indicating the battery needs to be replaced. Typical Communicator battery life with normal use is 8 to 9 hours.

Install a fully charged battery in the battery compartment with the arrow on the battery pointing outward, as shown in Figure 24. Slide it into the tracks on both sides of the compartment until its catch clicks securely in place.

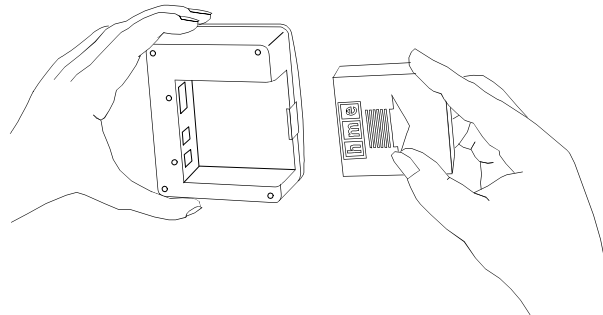

**Figure 24. Installing the COM430BP battery**

To remove the battery from a COM430BP belt-pac transceiver, slide the battery latch open and push the battery in the direction of the large arrow on the battery as shown in Figure 25.

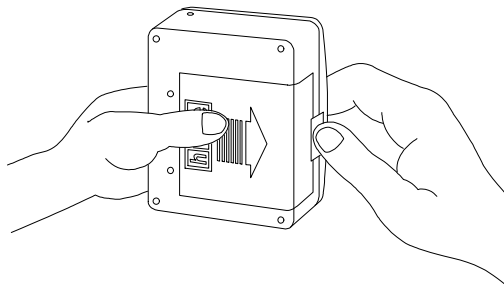

**Figure 25. Opening the COM430BP battery compartment**

## Installing and Removing HS30 Headset Batteries:

As a HS30 Headset battery weakens during routine use, you will hear a repeating tone in the earpiece, indicating the battery in the transceiver needs to be replaced. Typical HS30 battery life with normal use is 5 to 6 hours.

To install a fully charged battery in the HS30 Headset, insert the battery into the battery compartment in the headset transceiver until its catch clicks securely in place, as shown in Figure 26.

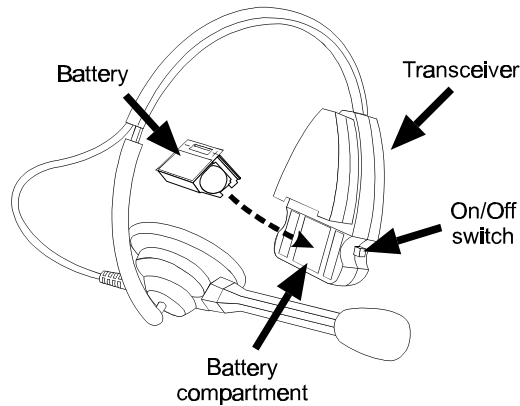

Figure 26. HS30 Headset

To remove the battery from a HS30 Headset, push the battery latch open and push the battery from the opposite side of the headset transceiver, in the direction of the arrow on the battery, as shown in Figure 27.

**CAUTION: Turn headset OFF before removing batteries.**

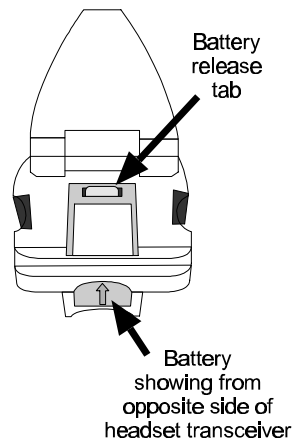

Figure 27. HS30 Headset transceiver

## Charging HS30 Batteries in the AC30 Battery Charger:

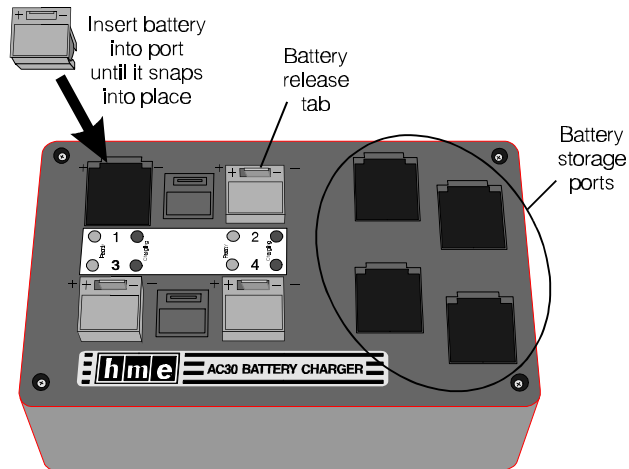
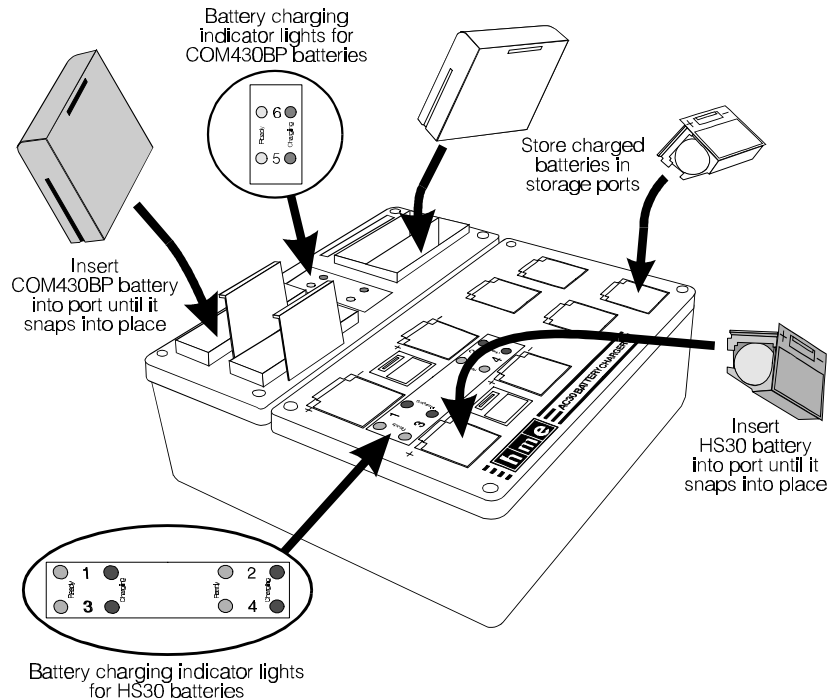

Figure 28. AC30 Battery Charger

Place up to four HS30 batteries in the charger to charge at the same time, as shown in Figure 28. A few seconds after each battery is placed in the charger, the red CHARGING light on the panel adjacent to the battery will indicate the battery charging status. See the CHARGING LIGHT STATUS TABLE for a detailed explanation of what is happening. When a battery is fully charged, the green READY light on the panel adjacent to it will light. (**approximately 2.5 hours**) It can then be placed back into a HS30 Headset.

**CAUTION:** *Do not remove batteries from the charger until the green READY light is lit, or the charger will reset and the charge cycle will begin again.*

## Charging Batteries with the AC930 Battery Charger:



**Figure 29. AC930 Battery Charger**

Place up to two COM430BP batteries and four HS30 batteries in the charger to charge at the same time. A few seconds after each battery is placed in the charger, the red CHARGING light on the panel adjacent to the battery, will indicate the battery charging status. See the CHARGING LIGHT STATUS TABLE for a detailed explanation of what is happening. When a battery is fully charged, the green READY light on the panel adjacent to it will light. (**approximately 4 hours for COM430BP batteries and 2.5 hours for HS30 batteries**) It can then be placed back into a COMMUNICATOR®.

**CAUTION:** *Do not remove batteries from the charger until the green READY light is lit, or the charger will reset and the charge cycle will begin again.*

CHARGING LIGHT STATUS TABLE - WITH BATTERY INSERTED		
RED CHARGING LIGHT	WHAT IT MEANS	WHAT TO DO
OFF	Charger doesn't see the battery	See NOTE
STEADY ON	Battery is being charged	Wait. Do not remove battery.
BLINKS: 2 seconds ON; 2 seconds OFF	Battery is being discharged.	Wait. Do not remove battery.
BLINKS: 2 times quick; 3 seconds OFF	DISCHARGE ERROR	Battery is not discharging properly. See NOTE.
BLINKS: 3 times quick; 3 seconds OFF	CHARGING ERROR	Battery is not charging properly. See NOTE.
BLINKS: 4 times quick; 2 seconds OFF	LOW BATTERY ERROR	See NOTE.
BLINKS: 5 times quick; 2 seconds OFF	CHARGING ERROR	See NOTE.
NOTE: Either the battery or the charger has a problem. Mark the battery and retry in a different slot. The battery is faulty if it has the same problem in a different slot AND a known-good battery passes in the same slots. The charger circuitry is faulty if a known-good BATTERY fails in the same slots.		

### III. SYSTEM 400 OPERATION

A.	<b>COM400BP or COM430BP COMMUNICATOR® Operation</b>		<b>COM400CC COMMUNICATOR® Operation</b>	
	In single or dual drive-thru operations, Communicator button "A" is for communication with the customer, and button "B" is for communication with other crew members wearing Communicators. In dual drive-thru operations, the Communicator button "C" is used to change lanes. Button "C" has no function in single drive-thru operations.		To operate the Communicator, use the control buttons shown in Figure 3 as follows. In both single and dual drive-thru operations, Communicator button "A" is for communication with the customer, and button "B" is for communication with other crew members wearing Communicators. In dual drive-thru operations, the "C" button is used to change lanes.	
	<b>ACTION</b>	<b>RESULT</b>	<b>ACTION</b>	<b>RESULT</b>
<b>Single Drive-Thru Lane Full-Duplex Operation</b>	If you are using the Communicator latching feature: Press and release button "A" to latch communication channel open for speaking and listening to customer. The channel will unlatch, ending communication with the customer, if; 1. you press and release button "A" again, or 2. you press button "B" or 3. the customer drives away If you are not using the Communicator latching feature: Press and hold button "A" while speaking and listening to customer. Release when transaction is completed.	Customer hears your voice and you hear customer's voice (two-way conversation). Everyone wearing a Communicator hears the communication.	If you are using the Communicator latching feature: Press and release button "A" to latch communication channel open for speaking and listening to customer. The channel will unlatch, ending communication with the customer, if; 1. you press and release button "A" again, or 2. you press button "B" or 3. the customer drives away If you are not using the Communicator latching feature: Press and hold button "A" while speaking and listening to customer. Release when transaction is completed.	Customer hears your voice and you hear customer's voice (two-way conversation). Everyone wearing a Communicator will hear the conversation.
	While customer is speaking, press the up ▲ or down ▼ arrow to adjust volume level.	Beep tones of increasing/decreasing frequency are heard in headset as volume level increases/ decreases. Customer's voice becomes louder or softer.	While customer is speaking, press the up ▲ or down ▼ arrow to adjust volume level.	Beep tones of increasing/decreasing loudness are heard in headset as volume increases/ decreases. Customer's voice becomes louder or softer.
	Press and hold button "B" to speak to other crew members wearing Communicators. Release to listen.	Other personnel wearing Communicators hear your voice in their headsets.	Press and hold button "B" to speak to other crew members wearing Communicators. Release to listen.	Other personnel wearing Communicators hear your voice in their headsets.
<b>Single Drive-Thru Lane Half-Duplex Operation</b>	Press and hold button "A" while speaking to customer.	Customer hears your voice. Everyone wearing a Communicator hears the communication.	Press and hold button "A" while speaking to customer.	Customer hears your voice.
	Release button "A" and listen to customer.	Customer's voice is heard in headsets of everyone wearing a Communicator.	Release button "A" and listen to customer.	Customer's voice is heard in headsets of everyone wearing Communicators.
	While customer is speaking, press the up ▲ or down ▼ arrow to adjust volume level.	Beep tones of increasing/decreasing frequency are heard in headset as volume level increases/decreases. Customer's voice becomes louder or softer.	While customer is speaking, press the up ▲ or down ▼ arrow to adjust volume level.	Beep tones of increasing/decreasing loudness are heard in headset as volume increases/ decreases. Customer's voice becomes louder or softer.
	Press and hold button "B" to speak to other crew members wearing Communicators. Release to listen.	Other personnel wearing Communicators hear your voice in their headsets.	Press and hold button "B" to speak to other crew members wearing Communicators. Release to listen.	Other personnel wearing Communicators hear your voice in their headsets.
<b>Dual Drive-Thru Lane Full-Duplex Operation</b>	If you are using the Communicator latching feature: Press and release button "A" to latch communication Channel 1 open for speaking and listening to customer in Lane 1. The channel will unlatch, ending communication with the customer, if; 1. you press and release button "A" again, or 2. you press button "B," or 3. you press button "C," or 4. the customer drives away If you are not using the Communicator latching feature: Press and hold button "A" while speaking and listening to customer in Lane 1 or 2. Release when transaction is completed. {	Customer hears your voice and you hear customer's voice (two-way conversation). Everyone wearing a Communicator hears the communication. NOTE: When transmitting in Lane 1 operation, the Communicator power light will blink rapidly. When transmitting in Lane 2 operation, the Communicator power light will blink rapidly 4 times, then pause and repeat. Lanes 1 and 2 have different sounding vehicle-present tones.	If you are using the Communicator latching feature: Press and release button "A" to latch communication Channel 1 open for speaking and listening to customer in Lane 1. The channel will unlatch, ending communication with the customer, if; 1. you press and release button "A" again, or 2. you press button "B," or 3. you press button "C," or 4. the customer drives away If you are not using the Communicator latching feature: Press and hold button "A" while speaking and listening to customer in Lane 1 or 2. Release when transaction is completed. {	Customer hears your voice and you hear customer's voice (two-way conversation). Everyone wearing Communicators set to the same channel hears the communication.
	While customer is speaking, press the up ▲ or down ▼ arrow to adjust volume level.	Beep tones of increasing/decreasing frequency are heard in headset as volume level increases/decreases. Customer's voice becomes louder or softer.	While customer is speaking, press the up ▲ or down ▼ arrow to adjust volume level.	Beep tones of increasing/decreasing loudness are heard in headset as volume increases/ decreases. Customer's voice becomes louder or softer.
	Press button "C" to switch to the other lane. {	You hear the customer's voice from the other lane.	Press button "C" to switch to Lane 2. {	You hear customer's voice from other lane.
	Press and hold button "B" to speak to other crew members wearing Communicators. Release to listen.	Other personnel wearing Communicators hear your voice in their headsets.	Press and hold button "B" to speak to other crew members wearing Communicators. Release to listen.	Other personnel wearing Communicators hear your voice in their headsets.
<b>Dual Drive-Thru Lane Half-Duplex Operation</b>	Press and hold button "A" while speaking to customer in Lane 1 or 2. {	Customer hears your voice. Everyone wearing Communicators hears the communication.	Press and hold button "A" while speaking to customer in Lane 2. {	Customer hears your voice. Everyone wearing Communicators hears the communication.
	Release button and listen to customer.	Customer's voice is heard in headsets of everyone wearing Communicators.	Release button and listen to customer.	Customer's voice is heard in headsets of everyone wearing Communicators.
	While customer is speaking, press the up ▲ or down ▼ arrow to adjust volume level.	Beep tones of increasing/decreasing frequency are heard in headset as volume level increases/ decreases. Customer's voice becomes louder or softer.	While customer is speaking, press the up ▲ or down ▼ arrow to adjust volume level.	Beep tones of increasing/decreasing loudness are heard in headset as volume increases/decreases. Customer's voice becomes louder or softer.
	Press button "C" to switch to the other lane. {	You hear the customer's voice from the other lane.	Press button "C" to switch to Lane 2. {	You hear customer's voice from other lane.
	Press and hold button "B" to speak to other crew members wearing Communicators. Release to listen.	Other personnel wearing Communicators hear your voice in their headsets.	Press and hold button "B" to speak to other crew members wearing Communicators. Release to listen.	Other personnel wearing Communicators hear your voice in their headsets.

{ In some dual-lane operations, button "C" is used to switch between Lanes 1 and 2, while button "A" is used to talk to customers in either lane.  
In some dual-lane operations, button "A" is used to talk to customers in Lane 1, and button "C" is used to talk to customers in Lane 2.

## B. Speed-Team Drive-Thru Operation

Speed team operation is used during high-volume times. Placing the speed-team button on the base station in the ON position will disable the speaker and microphone in the speaker post or menu board, and disable the vehicle-alert tone. An order taker wearing a Communicator relays orders from outside into the store using the "B" channel.

## C. Remote Display Operation

One or more R30 Remote Displays may be used with your System 400. Each remote display was set up by the installer to show the amount of time the current car has been at the menu board, speaker post or service window. A remote display shows the time for one location only. It begins counting when the car arrives and stops when the car leaves. The remote displays will only display time. They will not store or record information.

## D. Message Repeater Operation and Setup

To record messages on the System 400 internal message repeater, press the MESSAGE REPEATER button IN on the base station and do the following.

ACTION		RESULT
To record Message #1	Press and release the RECORD MODE button <b>once</b> on the System 400 base station.	The <b>red</b> MESSAGE RECORD light on the System 400 base station will come on.
	Press and hold button "B" on the COMMUNICATOR and talk into the headset microphone to record a message.	The MESSAGE RECORD light on the System 400 base station will begin blinking.
	Release button "B."	The record function will stop and the MESSAGE RECORD light will go off.
To record Message #2	Press and release the RECORD MODE button <b>twice</b> on the System 400 base station.	The <b>green</b> MESSAGE RECORD light on the System 400 base station will come on.
	Press and hold button "B" on the Communicator and talk into the headset microphone to record a message.	The MESSAGE RECORD light on the System 400 base station will begin blinking.
	Release button "B."	The record function will stop and the MESSAGE RECORD light will go off.

**After a new message has been recorded, or after the base station has lost and regained power, any message to the menu board will always be heard in the Communicator headset the first three times it plays.**

To change the message repeater setup, locate and set the S8 and S10 DIP switches at the bottom of the System 400 Base Station audio circuit board. Refer to the S8 AND S10 DIP SWITCH FUNCTIONS tables to the right for S8 and S10 switch functions.

If a System 30 Timer is installed with the System 400, the timer alert output can be used to trigger tones in the headset or to cause a message to be played. Set S8 and/or S10, switch #5 to OFF for an alert tone (triple beep), which will be heard only in headsets, or to ON for recorded messages to be heard through selected speakers and headsets.

If a System 400 is installed without a System 30 Timer, set both S8 and S10 switches #5 to OFF so the message repeater input will be triggered only by vehicle detector signals.

## S8 AND S10 DIP SWITCH FUNCTIONS

S8 — Switch Functions	
Switch	Function
1	ON - Allow inbound audio while message #1 is playing OFF - <b>DO NOT</b> allow inbound audio while message #1 is playing
2	ON - Transmit message #1 to Communicators OFF - <b>DO NOT</b> transmit message #1 to Communicators
3	ON - Send message #1 to outside speaker OFF - <b>DO NOT</b> send message #1 to outside speaker
4	ON - Send message #1 to ceiling speaker OFF - <b>DO NOT</b> send message #1 to ceiling speaker
5	ON - Trigger message #1 from alert input OFF - Trigger message #1 from vehicle present input
6	ON - Vehicle present tone is high pitched OFF - Vehicle present tone is low pitched
7	ON - 3 second delay OFF - No delay
8	NOT USED

S10 — Switch Functions	
Switch	Function
1	ON - Allow inbound audio while message #2 is playing OFF - <b>DO NOT</b> allow inbound audio while message #2 is playing
2	ON - Transmit message #2 to Communicators OFF - <b>DO NOT</b> transmit message #2 to Communicators
3	ON - Send message #2 to outside speaker OFF - <b>DO NOT</b> send message #2 to outside speaker
4	ON - Send message #2 to ceiling speaker OFF - <b>DO NOT</b> send message #2 to ceiling speaker
5	ON - Trigger message #2 from alert input OFF - Trigger message #2 from vehicle present input
6	NOT USED
7	ON - 3 second delay OFF - No delay
8	NOT USED

### NOTES:

#### Message #1 –

- Will be triggered by a vehicle present signal if S8 switch 5 is OFF. The playing message can be cancelled by pressing the "A" button on the Communicator.
- Will be triggered by an alert signal from the timer if S8 switch 5 is ON.
- Will be played to the locations selected on S8 switches 2, 3 and 4. See page 23.

#### Message #2 –

- Will be triggered by a vehicle present signal if S10 switch 5 is OFF. The playing message can be cancelled by pressing the "A" button on the Communicator.
- Will be triggered by an alert signal from the timer if S10 switch 5 is ON.
- Will be played to the locations selected on S10 switches 2, 3 and 4. See page 23.

**If S8 switch 5 and S10 switch 5 are both set to ON or OFF, Message #1 and Message #2 will be played alternately.**

## IV. HOW TO CARE FOR THE EQUIPMENT

### A. The COMMUNICATOR®

#### 1. Proper Handling of Headset Cables and Connectors

*HOW TO and HOW NOT TO handle Headset Cables and Connectors*

<b>ALWAYS</b>	<b>NEVER</b>
<p><b>A</b>lign the connector key and pins with key and holes in the receptacle when plugging the headset into the Communicator.</p> <p><b>F</b>asten cable to pouch with strain relief strap.</p> <p><b>C</b>lip the cable to your clothing with the clothing clips.</p> <p><b>G</b>rasp the connector to plug in or unplug the headset.</p> <p><b>U</b>se both hands to remove the headset from your head.</p> <p><b>U</b>se both hands to adjust the microphone position.</p> <p><b>H</b>andle the headset cable with care.</p> <p><b>C</b>arry and hang the headset by its metal headband.</p>	<p><b>T</b>wist headset connector into Communicator receptacle.</p> <p><b>A</b>llow cable to be stressed at connector.</p> <p><b>A</b>llow cable to hang freely.</p> <p><b>G</b>rasp and pull cable to unplug headset.</p> <p><b>R</b>emove headset with only one hand.</p> <p><b>A</b>adjust microphone position with only one hand.</p> <p><b>P</b>ull, twist, bend or knot the headset cable.</p> <p><b>C</b>arry or hang the headset by its cable.</p>

#### 2. Cleaning the COMMUNICATOR®

The following cleaning procedure is recommended at least once each month.

- ! If the Communicator has a belt and/or pouch, remove it from the pouch. Wash the belt and/or pouch in a washing machine with normal laundry detergent. Dry them in a dryer or hang them up to dry.
- ! Remove the battery from the Communicator.
- ! Clean the Communicator with a damp sponge. Wet the sponge and wring it out so it is damp, not dripping wet. Spray household cleaner on the sponge (NOT DIRECTLY ON THE EQUIPMENT). Clean the Communicator with the sponge, and dry it thoroughly.
- ! Clean the metal battery contacts on the battery with alcohol on a cotton swab. Wet the tip of the swab with alcohol and squeeze the excess alcohol from it. Wipe each contact with the swab, and be certain all the contacts are dry before installing the batteries.
- ! Place the battery back in the Communicator and, if there is a pouch, place the Communicator back in the pouch and fasten the strap securely over it.
- ! Clean the headset and cable with a damp sponge sprayed with household cleaner. The foam muff on the headset earpiece is easily replaced for sanitary purposes. To order extra foam muffs, call your local HME sales representative.

### B. The Battery Charger

Avoid splashing water or grease on the battery charger. Clean the battery charger monthly as follows:

**CAUTION: Always unplug the battery charger before cleaning it.**

- ! Remove all batteries from the battery charger.
- ! Clean the battery charger case with a damp sponge. Wet the sponge and wring it out so it is damp, not dripping wet. Spray household cleaner on the sponge (NOT DIRECTLY ON THE EQUIPMENT). Clean the battery charger with the sponge, and dry it thoroughly.
- ! Wet the tip of a cotton swab with rubbing alcohol, and squeeze the excess alcohol from the swab. Wipe the metal contacts inside each battery port with the damp swab. Allow the contacts to dry before placing batteries in the ports.

V. **IN CASE OF PROBLEMS** (Refer to the circuit board illustration on page 23)

<b>TROUBLESHOOTING CHECKLIST</b>		
<b>Problem</b>	<b>Probable Cause</b>	<b>Solution</b>
No sound in headset when you press COMMUNICATOR® button "A" and speak into headset microphone.	Power is off at base station.	Check circuit breaker for building.
	Power supply in base station is not working.	Check power supply indicator lights on base station. If any light is not lit, be certain AC power adapter is plugged into AC electrical outlet, and connected to J2 connector on audio circuit board in base station.
	Communicator not turned on.	Turn Communicator on by pushing ON/OFF button. Be certain light goes on.
	Volume not set correctly.	Push volume-control buttons to adjust volume.
	Headset connector not plugged in properly. (This applies only to COM400BP and COM400CC.)	Plug headset connector firmly into Communicator receptacle.
	Headset defective.	Replace with another headset.
	Low or dead battery.	Check ON/POWER light. If not lit, replace battery.
	Communicator failed.	Use another Communicator. Call HME. *
<b>COM430 Only</b>	HS30 Headset not turned on.	Press ON/Off switch to turn headset on.
	HS30 Headset battery is low or dead.	Replace battery.
Communicator channel "A" or "B" functions not working.	Communicator not turned ON.	Turn Communicator on.
	Dead or weak battery.	Replace battery.
	Communicator or base station failure. Channel "A" or "B" light and RECEIVE light on base station do not light when Communicator button "A" or "B" is pressed.	Use another Communicator. Call HME. *
"C" button does not switch between channels in a dual-lane drive-thru.	Switch setting on Communicator incorrect.	Check S1 switch on Communicator. Switch #9 should be ON.
Outbound sound too low.	Outbound volume set too low for environment.	Turn outside speaker volume control (R128 in base station) clockwise with small standard (slotted) screwdriver until level is satisfactory.
No outbound sound; customer cannot hear anything.	System may be set for speed-team operation. See pages 1 and 19.	Be certain SPEED TEAM button on base station is out (OFF).
	Loose wires on base station circuit board.	Check speaker wire connections on switcher circuit board.
	Defective speaker or base station.	Call HME. *

\* For assistance, call HME at 1-800-848-4468, or Fax 858-552-0172.



<b>Problem</b>	<b>Probable Cause</b>	<b>Solution</b>
No inbound sound from customer (in half-duplex operation).	System may be set for speed-team operation. See pages 1 and 19.	Be certain SPEED TEAM button on base station is out (OFF).
	Base station may be set for wrong drive-thru mode (full or half-duplex).	Check S6 switch on base station circuit board. Switch #1 should be ON for full-duplex OFF for half-duplex
Personnel hear static only in headsets.	Transmitter antenna connection on base station is loose.	Tighten transmitter antenna connection. (the antenna on top, left of base station.)
	No power to base station.	Check base station power adapter connections.
	Circuit board defective.	Call HME. *
<b>COM430 Only</b>	Interference from nearby equipment.	Person wearing Communicator should move to different location.
	Belt-pac and/or headset not properly worn.	Be certain belt-pac is securely clipped onto belt or waistband, close to body, and both belt-pac unit and headset are in upright positions.
Personnel hear customer in headsets or ceiling speaker, but cannot hear each other.	Receiver antenna connection on base station is loose.	Tighten receiver antenna connection. (the antenna on top, right of base station.)
	Status lights are not lit. Circuit board is defective.	Call HME. *
	Defective COMMUNICATOR® or headset.	Call HME. *
No tone or sound in headset or ceiling speaker when vehicle drives into drive-thru lane.	Power interruption has caused unbalanced detecting circuit.	When no vehicle is in the drive-thru lane, press vehicle detector override switch on base station to RESET position, then back to NORMAL position.
	System may be set for speed-team operation. See pages 1 and 19.	Be certain SPEED TEAM button on base station is out (OFF).
	Connector may be loose.	Check all connectors. Call HME. *
Personnel cannot hear outside customers in headset or ceiling speaker.	Loose wires on base station circuit board connector.	Be certain wires are securely connected in base station.
	System may be set for speed-team operation. See pages 1 and 19.	Be certain SPEED TEAM button on base station is out (OFF).
	Outside speaker or audio circuit board has failed.	Call HME. *
Communicator has intermittent sound.	Low battery.	Replace battery.
	Defective headset cable. (This applies only to COM400BP and COM400CC.)	Use another headset. Call HME. *
Headset does not become silent after customer has driven away.	OVERRIDE/RESET, NORMAL switch on base station is in the OVERRIDE/RESET position.	Place switch in the NORMAL position.
	Vehicle detector is locked up.	Press OVERRIDE/RESET switch twice.
Battery charger not working.	Charger not plugged in.	Plug in battery charger. If still not working, call HME. *
Can not record message.	Message repeater not turned on.	Turn message repeater on.
Message will not play.		

\* For assistance, call HME at 1-800-848-4468, or Fax 858-552-0172.

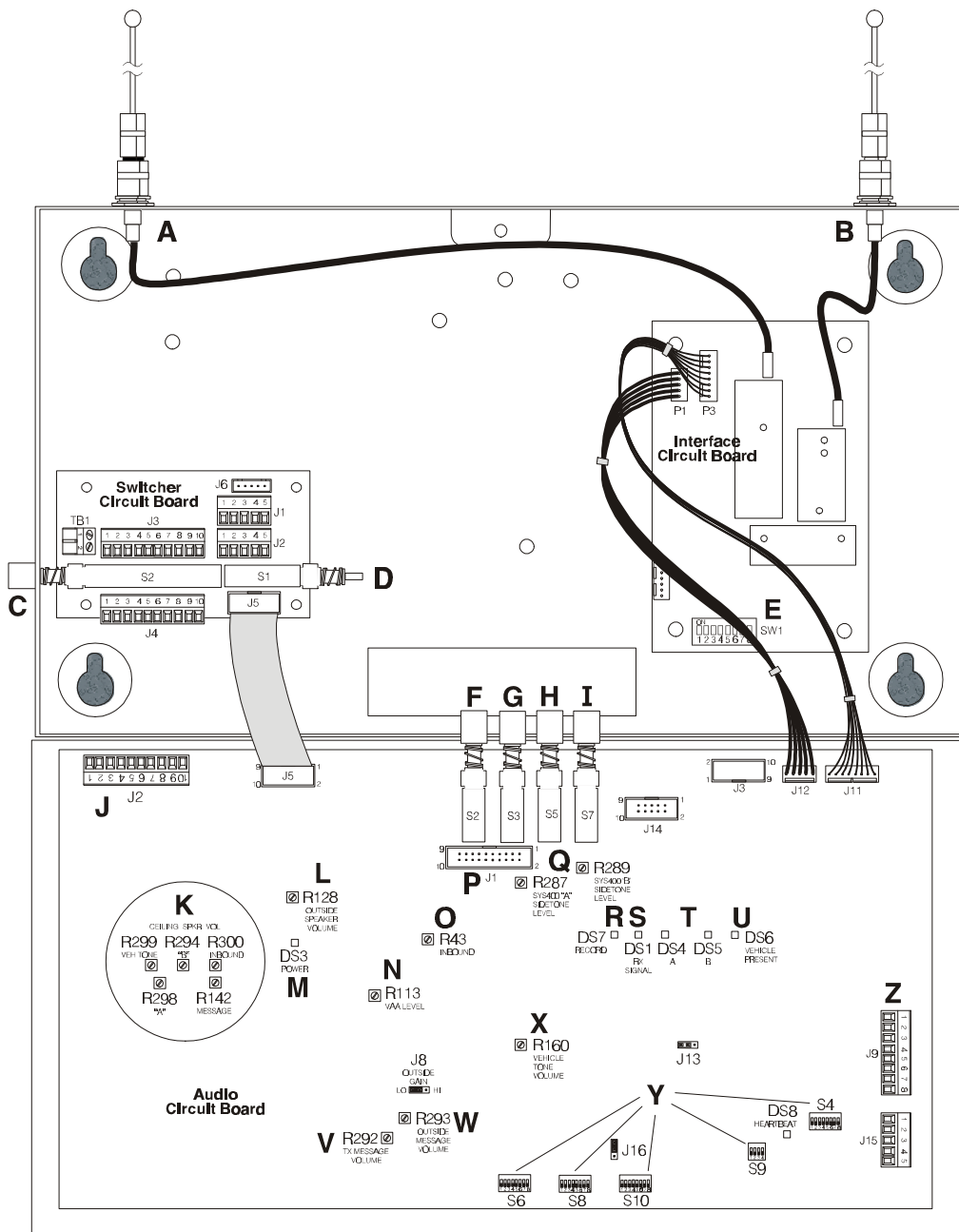

Figure 30.

### Base station circuit boards

- |  |  |
|--|--|
| <ul style="list-style-type: none"> <li>A - Transmitter antenna connector</li> <li>B - Receiver antenna connector</li> <li>C - Wired backup system switch - S2</li> <li>D - DM2 select switch - S1</li> <li>E - Frequency select switch - SW1</li> <li>F - Record message switch - S2</li> <li>G - Message repeater ON/OFF switch - S3</li> <li>H - Speed team switch - S5</li> <li>I - Vehicle detector override switch - S7</li> <li>J - Power and ceiling speaker connector - J2</li> <li>K - Ceiling speaker volume controls - R142, R294, R298, R299, R300</li> <li>L - Outside speaker volume control - R128</li> <li>M - Power supply LED - DS3</li> </ul> | <ul style="list-style-type: none"> <li>N - VAA level control - R113</li> <li>O - Inbound volume control - R43</li> <li>P - Automatic test equipment connector - J1</li> <li>Q - Channel "A" and "B" sidetone level controls - R287, R289</li> <li>R - Message record LED - DS7</li> <li>S - Receiver LED - DS1</li> <li>T - Channel "A" and "B" LEDs - DS4, DS5</li> <li>U - Vehicle present LED - DS6</li> <li>V - Transmitter message volume control - R292</li> <li>W - Outside message volume control - R293</li> <li>X - Vehicle present tone volume control - R160</li> <li>Y - System configuration switches - S4, S6, S8, S9, S10</li> <li>Z - Base-to-base connector (for dual drive-thru operations) - J9</li> </ul> |
|--|--|

## VI. SPECIFICATIONS

### Base Station

1.	Voltage input	16VAC $\pm$ 2.5V
2.	AC current input	350mA nominal, 1.4A maximum
3.	Audio distortion	<5% maximum level
4.	Outside speaker output	3 watts RMS into 8 ohms
5.	Ceiling speaker power	3 watts RMS into 8 ohms
6.	Message repeater	Message duration - 16 seconds
7.	Controls/Switches	2-position vehicle detector switch (Normal - Override/Reset) 2-position "Speed Team" ON/OFF switch 2-position "Message Repeater" ON/OFF switch 1-position "Record" switch 4-position RS485 bias/term switch Outside speaker volume control Outside speaker Hi-Lo volume jumper Vehicle present tone level control "A" sidetone "B" sidetone Inbound volume control VAA level control Ceiling speaker volume control Vehicle present tone volume control (3) 8-position DIP switches 4-position frequency select switch Wireless/wired system select switch Horn speaker/DM1 select switch
8.	TX/RX Frequency	FCC Part 90
9.	Dimensions	8.2"H x 14.2"W x 3.5"D (208mm x 361mm x 89mm)
10.	Weight	5.5 lbs (2.49kg) maximum

### COM400CC COMMUNICATOR®

1.	Battery (NiMH)	8 hours
2.	RF Frequency	Receive — FCC Part 90 Transmit — FCC Part 90
3.	Dimensions	3d"H x 4c"W x 1½"D (86mm x 114mm x 38mm)
4.	Weight	12 ounces (3.40kg) — including battery
5.	Controls	Buttons "A," "B" and "C" Power control Volume control
6.	Indicator	Red LED Solid when receiving only. Blinking when transmitter is activated, or on secondary lane for dual-lane systems
7.	Connector	LT

### COM400BP COMMUNICATOR®

- |    |                |  |
|----|----------------|--|
| 1. | Battery (NiCd) | 8-10 hours   |
| 2. | RF Frequency   | Receive — FCC Part 90<br>Transmit — FCC Part 90                                |
| 3. | Weight         | 11 ounces (3.12kg) — including battery   |
| 4. | Controls       | Buttons "A," "B" and "C"<br>Power On/Off button<br>Volume control buttons      |
| 5. | Indicator      | Red LED<br>Solid when receiving only<br>Blinking when transmitter is activated |
| 6. | Connector      | 5-pin DIN  |

### COM430BP COMMUNICATOR®

- |    |                         |  |
|----|-------------------------|--|
| 1. | Belt-pac Battery (NiCd) | 8-10 hours   |
|    | Headset Battery (NiMH)  | 5-6 hours  |
| 2. | RF Frequency            | Receive — FCC Part 90<br>Transmit — FCC Part 90                                |
| 3. | Weight                  | 11 ounces (3.12kg) — including battery   |
| 4. | Controls                | Buttons "A," "B" and "C"<br>Power On/Off button<br>Volume control buttons      |
| 5. | Indicator               | Red LED<br>Solid when receiving only<br>Blinking when transmitter is activated |

### AC30 Battery Charger (for HS30 Headset NiMH batteries)

- |    |                         |   |
|----|-------------------------|---|
| 1. | Voltage input:          | 16.5VAC   |
| 2. | Number of charge ports: | 4   |
| 3. | Charge time:            | 2-3 hours   |
| 4. | Dimensions:             | 7.5"L x 4"W x 2¾"D (191mm x 102mm x 70mm)                             |
| 5. | Weight:                 | 20.22 oz (.573Kg)   |
| 6. | Indicators:             | Battery-charging (red) LEDs, 4 ea<br>Battery-ready (green) LEDs, 4 ea |

### AC420 Battery Charger (for COM400BP or COM430BP NiCd batteries)

- |    |                         |   |
|----|-------------------------|---|
| 1. | Voltage input:          | 16.5VAC   |
| 2. | Number of charge ports: | 4   |
| 3. | Charge time:            | 4-8 hours   |
| 4. | Dimensions:             | 8"L x 12"W x 3.5"D (203mm x 305mm x 89mm)                             |
| 5. | Weight:                 | 24 oz (.680Kg) - not including AC adapter                             |
| 6. | Indicators:             | Battery-charging (red) LEDs, 4 ea<br>Battery-ready (green) LEDs, 4 ea |

**AC900 Battery Charger** (for COM400CC NiMH batteries)

1. Voltage input: 16.5VAC
2. Number of charge ports: 4
3. Charge time: 2 hours
4. Dimensions: 7.5"L x 4"W x 3<sup>7</sup>/<sub>8</sub>"D (191mm x 102mm x 78mm)
5. Weight: 23.04 oz (.653Kg)
6. Indicators: Battery-charging (red) LEDs, 4 ea  
Battery-ready (green) LEDs, 4 ea

**AC910 Battery Charger** (for COM400BP NiCd and COM400CC NiMH batteries)

1. Voltage input: 16.5VAC
2. Number of charge ports: 4 for COM400CC NiMH batteries  
2 for COM400BP NiCd batteries
3. Charge time: 2 hours for COM400CC NiMH batteries  
4-8 hours for COM400BP NiCd batteries
4. Dimensions: 7.5"L x 7.5"W x 3<sup>7</sup>/<sub>8</sub>"D (191mm x 191mm x 78mm)
5. Weight: 31.94 oz (.906Kg)
6. Indicators: Battery-charging (red) LEDs, 6 ea  
Battery-ready (green) LEDs, 6 ea

**AC930 Battery Charger** (for COM430BP NiCd and HS30 Headset NiMH batteries)

1. Voltage input: 16.5VAC
2. Number of charge ports: 4 for COM430 headset NiMH batteries  
2 for COM400 belt-pac NiCd batteries
3. Charge time: 2-3 hours for COM430 headset NiMH batteries  
4-8 hours for COM400BP belt-pac NiCd batteries
4. Dimensions: 7.5"L x 7.5"W x 3<sup>7</sup>/<sub>8</sub>"D (191mm x 191mm x 78mm)
5. Weight: 29.10 oz (.825Kg)
6. Indicators: Battery-charging (red) LEDs, 6 ea  
Battery-ready (green) LEDs, 6 ea

## VII. ACCESSORIES AND OPTIONAL EQUIPMENT

The following optional equipment is available for use with your System 400.  
To order any of these products, call the HME Sales Department at (858) 535-6060.

Equipment	Model Number
COMMUNICATOR <sup>®</sup>	COM400BP
COMMUNICATOR <sup>®</sup>	COM400CC
COMMUNICATOR <sup>®</sup>	COM430BP
Battery (NiCd) for COM400 or COM430BP COMMUNICATOR <sup>®</sup>	BAT400
Battery (NiMH) for HS30	BAT30
Battery (NiMH) for COM400CC	BAT900
Headset	HS9
Headset Earmuff	no model number
Headset	HS30
Earpiece/Microphone	HS4
Ultrasonic Vehicle Detector	DU2/DU3
Vehicle Detector Board	VDB101
Vehicle Detector Loop (underground)	VDL100
Message Repeater	MR300
Remote Display	R30
Ceiling Speaker	MM100
Variable, Low-Profile Speaker	MM2500
Microphone	DM2

## VIII. FCC NOTICE

HME wireless radio frequency systems are type-accepted in the United States under Part 90 of the Federal Communications Commission (FCC) Code of Federal Regulations, and type-approved in Canada by Industry and Science Canada. Because licensing depends on the system's application, it is the user's responsibility to apply for a license from the FCC in the U.S. and its possessions, or from Industry and Science Canada in Canada and its territories. Licensing requirements vary from country to country. Contact your local licensing agency for specific requirements.

This device complies with Part 15 of the FCC rules. Operation is subject to the following two conditions: (1) This device may not cause harmful interference, and (2) This device must accept any interference received, including interference that may cause undesired operation.

**NOTE:** This equipment has been tested and found to comply with the limits for a Class A digital device, pursuant to Part 15 of the FCC rules. These limits are designed to provide reasonable protection against harmful interference when the equipment is operated in a commercial environment. This equipment generates, uses and can radiate radio frequency energy and, if not installed and used in accordance with the instruction manual, may cause harmful interference to radio communication. Operation of this equipment in a residential area is likely to cause harmful interference, in which case the user will be required to correct the interference at his own expense.

Changes or modifications not expressly approved by HM Electronics, Inc. could void the users authority to operate this equipment.